

GAS-FIRED COMMERCIAL WATER HEATER

A Spanish language version of these instructions is available by contacting the company listed on the rating plate.

La versión española de estas instrucciones se puede obtener al escribirle a la fábrica cuyo nombre aparece en la placa de especificaciones.

INSTALLATION & OPERATING INSTRUCTION MANUAL

WARNING: If the information in these instructions is not followed exactly, a fire or explosion may result causing property damage, personal injury or death.

FOR YOUR SAFETY

- Do not store or use gasoline or other flammable, combustible, or corrosive vapors and liquids in the vicinity of this or any other appliance.
- **WHAT TO DO IF YOU SMELL GAS**
 - Do not try to light any appliance.
 - Do not touch any electrical switch; do not use any phone in your building.
 - Immediately call your gas supplier from a neighbor's phone. Follow the gas supplier's instructions.
 - If you cannot reach your gas supplier, call the fire department.
- Installation and service must be performed by a qualified installer, service agency or the gas supplier.

For safety, convenience, and best performance, we recommend this water heater be installed and serviced by a plumbing professional.

TABLE OF CONTENTS

	page
GENERAL INFORMATION	3
INSTALLATION.....	5
Locating The Water Heater	5
Minimum Clearances.....	8
Venting	14
Combustion Air Supply.....	16
Water Connections.....	18
Gas Connections	21
GENERAL OPERATION	22
Wiring Diagrams	
Standard Pilot Wiring Diagram.....	23
Spark Ignition Wiring Diagram.	24
Lighting and Shutdown Instructions	
Standard Pilot Models.....	25
Spark Ignition Models.	26
Temperature Adjustment.....	27
Burner Flame Check	29
MAINTENANCE	30
OPERATING & TROUBLESHOOTING GUIDE.....	34
TEMPERATURE CONTROL CHECKOUT	39
PARTS LIST & DRAWING	40
INSTALLATION INSTRUCTIONS FOR POTABLE WATER AND SPACE HEATING	41
NOTES	43

GENERAL INFORMATION

This gas-fired water heater is design certified by the American Gas Association Laboratories under the applicable American National Standard, Z21.10.1 or Z21.10.3 (as indicated on the rating plate), available from the American Gas Association, 1515 Wilson Blvd., Arlington, VA 22209.

The warranty for this water heater is in effect only when the water heater is installed, adjusted, and operated in accordance with these Installation and Operating Instructions. The warranty does not cover damage or injury caused by the use of any energy-saving devices (other than those authorized by the manufacturer) in conjunction with this water heater. The use of unauthorized energy-saving devices may decrease the life of the water heater and endanger life and/or property. The manufacturer will not be liable for any damage, injury, or loss of life resulting from alteration and/or failure to comply with these instructions.

This water heater has been equipped for use with **one type of gas only**. Compare the information provided on the rating plate, affixed to the front of the water heater, making sure that the gas stated on the rating plate is the same as the gas to be used.

▲CAUTION

Do not attempt to use this water heater with any gas other than the type listed on the rating plate. Do not attempt to convert this water heater for use with a gas other than the type for which it is equipped. Failure to use the proper gas can create an unsafe condition resulting in property damage, bodily injury, or death. Consult your local gas supplier or gas company if there are any questions.

This water heater must be installed in accordance with local codes. In the absence of local codes, it must be installed in compliance with the National Fuel Gas Code (ANSI Z223.1-Latest Edition), or in Canada CAN/CGA B149.1 Natural Gas Installation Code (Latest Edition) or CAN/CGA B149.2 Propane Installation Code (Latest Edition).

For installations in high altitude regions, this water heater must be ordered from the supplier to the manufacturer's specifications for that particular altitude. Contact the company listed on the rating plate when ordering high altitude constructed water heaters.

This water heater has been designed and certified for the purpose of heating potable water. The installation and use of this water heater for any purpose other than the heating of potable water may cause damage to the water heater, create a hazardous condition, and nullify the warranty.

▲ CAUTION

Incorrect operation of this appliance may create a hazard to life and property and will nullify the warranty.

▲ DANGER

Do not store or use gasoline or other flammable, combustible, or corrosive vapors and liquids in the vicinity of this or any other appliance.

IMPORTANT

Before proceeding, please inspect the water heater and components for possible damage. **DO NOT** install and damaged components. If damage is evident, please contact the supplier where the water heater was purchased or the manufacturer listed on the rating plate for replacement parts.

INSTALLATION

Locating The Water Heater

WARNING

Water heaters are heat producing appliances. To avoid damage or injury there shall be no materials stored against the water heater and proper care shall be taken to avoid unnecessary contact (especially by children) with the water heater components. **UNDER NO CIRCUMSTANCES SHALL FLAMMABLE MATERIALS, SUCH AS GASOLINE OR PAINT THINNER BE USED OR STORED IN THE VICINITY OF THIS WATER HEATER, VENT-AIR INTAKE SYSTEM OR IN ANY LOCATION FROM WHICH FUMES COULD REACH THE WATER HEATER OR VENT-AIR INTAKE SYSTEM.**

This water heater must NOT be installed in any location where gasoline or flammable vapors are likely to be present, unless the installation is such to eliminate the probable ignition of gasoline or flammable vapors.

The location of this water heater is of the utmost importance. Before installing this water heater, you should read the Installation section of these instructions. After reading these Installation and Operating Instructions, select a location for the water heater where the floor is level and is easily accessible to water lines, gas supply (type identified on the rating plate), an adequate open drain, and a chimney or exhaust gas vent. **DO NOT locate the water heater where water lines could be subjected to freezing temperatures. Make sure the cold water pipes are not located directly above the gas control box or any other electrical control so that condensate during humid weather does not drip on the controls**

Adequate clearances shall be provided for easy access to controls by service personnel to enable proper cleaning, servicing, and operation of the water heater. Under no circumstances is the front of the water heater to be placed in a position where the burner tray assembly cannot slide out for removal when servicing.

Installation (Locating The Water Heater) continued

Water heater corrosion and component failure can be caused by the heating and breakdown of airborne chemical vapors. Examples of some typical compounds that are potentially corrosive are: spray can propellants, cleaning solvents, refrigerator and air conditioning refrigerants, swimming pool chemicals, calcium and sodium chloride, waxes and process chemicals. These materials are corrosive at very low concentration levels with little or no odor to reveal their presence. **NOTE: DAMAGE TO THE WATER HEATER CAUSED BY EXPOSURE TO CORROSIVE VAPORS IS NOT COVERED BY THE WARRANTY. DO NOT OPERATE THE WATER HEATER IF EXPOSURE HAS OR WILL OCCUR. DO NOT STORE ANY POTENTIALLY CORROSIVE COMPOUNDS IN THE VICINITY OF THE WATER HEATER.**

 WARNING

Liquefied petroleum gases/propane gas are heavier than air and will remain at floor level if there is a leak. Basements, crawl spaces, closets and areas below ground level will serve as pockets for accumulation of leaking gas. Before lighting, smell all around the appliance area for gas. Be sure to smell next to the floor.

IF YOU SMELL GAS:

- Do not try to light any appliance.
- Do not touch any electric switch; do not use any telephone in your building.
- Immediately call your gas supplier from a telephone in another building. Follow the gas supplier's instructions.
- If you cannot reach your gas supplier, call the fire department.

DO NOT OPERATE APPLIANCE UNTIL LEAKAGE IS CORRECTED!

▲WARNING

DO NOT ATTEMPT TO LIGHT ANY GAS APPLIANCE IF YOU ARE NOT CERTAIN OF THE FOLLOWING:

- Liquefied petroleum gases/propane gas and natural gas have an odorant added by the gas supplier that aids in detection of the gas.
- Most people recognize this odor as a “sulfur” or “rotten egg” smell.
- Other conditions, such as “odorant fade” can cause the odorant to diminish in intensity, or “fade”, and not be as readily detectable.
- If you have a diminished sense of smell, or are in any way unsure of the presence of gas, immediately contact your gas supplier from a telephone in another building.
- Gas detectors are available. Contact your gas supplier or plumbing professional for more information.

Proper venting practices must be considered when selecting a location for this water heater. For exact venting specifications, please consult the Venting section, located on page 10, of these Installation and Operating Instructions.

This water heater must be located in an area where leakage of the tank, water line connections, or the combination temperature and pressure relief valve will not result in damage to the area adjacent to the water heater or to lower floors of the structure. When such locations cannot be avoided, a suitable drain pan must be installed under the water heater. The drain pan must be no greater than 1-½ inches (3.8 cm) deep and have a minimum length and width of at least four (4) inches (10.2 cm) measured from the jacket of the water heater. The drain pan, as described above, can be purchased from your plumbing professional. The drain pan must be piped to an adequate drain. The piping must be at least ¾ inch (1.9 cm) in diameter and pitched for proper drainage.

It is recommended that a minimum clearance of four (4) inches (10.2 cm) be provided on the side of the water heater for servicing and maintenance of the combination temperature and pressure relief valve.

Minimum Clearances

▲WARNING

Failure to adhere to these installation and operating instructions may create a hazard to life and property and will nullify the warranty.

This installation shall allow access to the front of the water heater and adequate clearance shall be provided for servicing and operating this water heater. The water heater may be installed on either a combustible or non-combustible floor. If the water heater is to be installed directly on carpeting, it shall be installed on top of a metal or wood panel (or equivalent) extending beyond the full width and depth of the appliance by at least three (3) inches (7.6 cm) in any direction or, if the appliance is to be installed in an alcove or closet, the entire floor shall be covered by the panel. The minimum clearances to combustibles for this water heater are given in the tables on pages 9 through 13. A minimum of 24 inches front clearance shall be provided for inspection and servicing.

▲CAUTION

The National Fuel Gas Code (ANSI Z233.1-or latest edition) and CAN/CGA (B149.1-or latest edition), expressly prohibits the following:

- a) Installation of a water heater in a bathroom, bedroom, or any occupied room normally kept closed.**
- b) Installation of a water heater in a garage, unless the unit is installed so that the burner and ignition devices are at least eighteen (18) inches (45.8 cm) above floor level and protected to avoid damage by a moving vehicle.**

Installation (Minimum Clearances) continued-

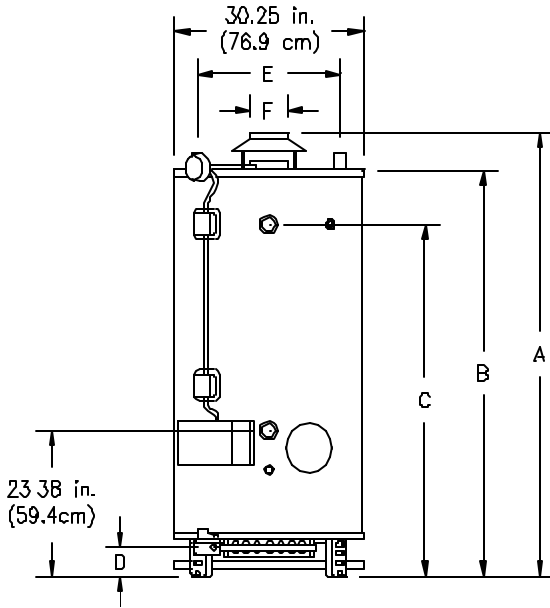

Figure 1

Non-Flue Damper Models and Flue Damper Models

Model Description			A (in)	B (in)	C (in)	D (in)	E (in)	F (in)	Clearances *		
Capacity (GAL)	Input (BTU/hr)								Sides and Rear (in)	Flue or Vent (in)	Ceiling (in)
	Nat.	LP									
100	199,999	199,999	74.88	65.19	56.38	4.56	23	6	2	6	20
100	250,000	225,000	74.88	65.19	56.38	4.56	23	6	2	6	20
100	270,000	250,000	74.88	65.19	56.38	4.56	23	6	2	6	20
100	300,000	300,000	75.44	65.19	56.38	4.56	23	7	2	6	20
80	399,999	375,000	71.06	60.03	51.56	10.19	N/A	8	6	6	20
80	450,000	425,000	69.03	60.03	51.56	10.19	N/A	10	6	6	20
80	505,000	475,000	69.03	60.03	51.56	10.19	N/A	10	6	6	20

Model Description			A (m)	B (m)	C (m)	D (cm)	E (cm)	F (cm)	Clearances *		
Capacity (Litres)	Input (kW/hr)								Sides and Rear (cm)	Flue or Vent (cm)	Ceiling (cm)
	Nat.	LP									
378.5	58.7	58.7	1.90	1.66	1.43	11.6	58.4	15.2	5.1	15.3	50.8
378.5	73.3	66.0	1.90	1.66	1.43	11.6	58.4	15.2	5.1	15.3	50.8
378.5	79.3	73.3	1.90	1.66	1.43	11.6	58.4	15.2	5.1	15.3	50.8
378.5	88.0	88.0	1.92	1.66	1.43	11.6	58.4	10.2	5.1	15.3	50.8
302.8	117.3	109.9	1.81	1.53	1.31	25.9	N/A	10.2	15.3	15.3	50.8
302.8	131.9	124.6	1.75	1.53	1.31	25.9	N/A	25.4	15.3	15.3	50.8
302.8	148.0	139.3	1.75	1.53	1.31	25.9	N/A	25.4	15.3	15.3	50.8

1. N/A - Denotes not available.

Installation (Minimum Clearances) continued-

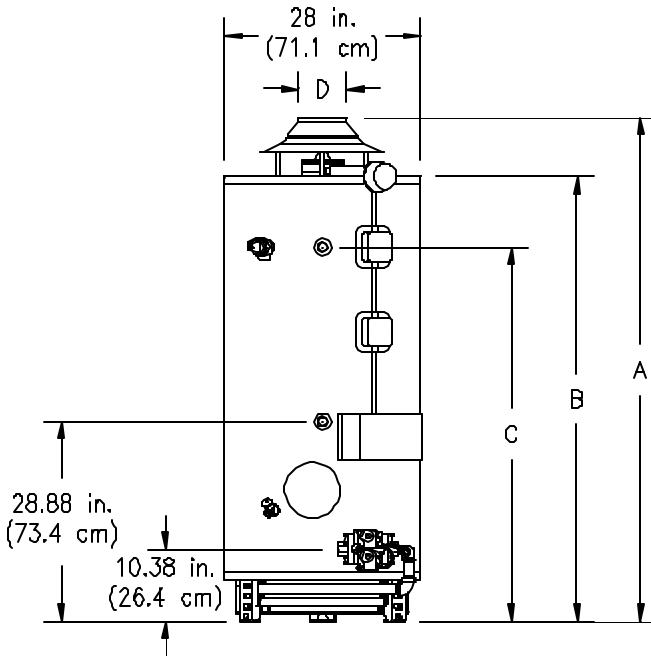

Figure 2

Non-Flue Damper Models

Model Designation		A (in.)	B (in.)	C (in.)	D (in.)	Clearances *		
Capacity (GAL)	Input (BTU/hr)					Sides and Rear (in.)	Flue or Vent (in.)	Ceiling (in.)
65	370,000	71.38	64.38	54.13	8	6	6	20
65	399,999 (NAT ONLY)	71.38	64.38	54.13	8	6	6	20
75	300,000	72.00	64.38	54.13	7	6	7	20
80	425,000	81.00	75.38	64.25	10	6	6	20
80	505,000	81.00	75.38	64.25	10	6	6	20

Model Designation		A (m)	B (m)	C (m)	D (cm)	Clearances *		
Capacity (Litres)	Input (kW/hr)					Sides and Rear (cm)	Flue or Vent (cm)	Ceiling (cm)
246.1	108.5	1.82	1.64	1.38	20.4	15.3	15.3	50.8
246.1	117.3 (NAT ONLY)	1.82	1.64	1.38	20.4	15.3	15.3	50.8
283.9	88.0	1.83	1.64	1.38	17.8	15.3	17.8	50.8
302.8	124.6	2.06	1.92	1.64	25.4	15.3	15.3	50.8
302.8	148.0	2.06	1.92	1.64	25.4	15.3	15.3	50.8

Flue Damper Models (Figure 2)

Model Designation		A (in.)	B (in.)	C (in.)	D (in.)	Clearances *		
Capacity (GAL)	Input (BTU/hr)					Sides and Rear (in.)	Flue or Vent (in.)	Ceiling (in.)
65	370,000	73.38	64.38	54.13	8	6	6	20
65	399,999 (NAT ONLY)	73.38	64.38	54.13	8	6	6	20
75	300,000	74.63	64.38	54.13	7	6	7	20
80	425,000	83.50	75.38	64.25	10	6	6	20
80	505,000	83.50	75.38	64.25	10	6	6	20

Model Designation		A (m)	B (m)	C (m)	D (cm)	Clearances *		
Capacity (Litres)	Input (kW/hr)					Sides and Rear (cm)	Flue or Vent (cm)	Ceiling (cm)
246.1	108.5	1.87	1.64	1.38	20.4	15.3	15.3	50.8
246.1	117.3 (NAT ONLY)	1.87	1.64	1.38	20.4	15.3	15.3	50.8
283.9	88.0	1.87	1.64	1.38	17.8	15.3	17.8	50.8
302.8	124.6	2.12	1.92	1.64	25.4	15.3	15.3	50.8
302.8	148.0	2.12	1.92	1.64	25.4	15.3	15.3	50.8

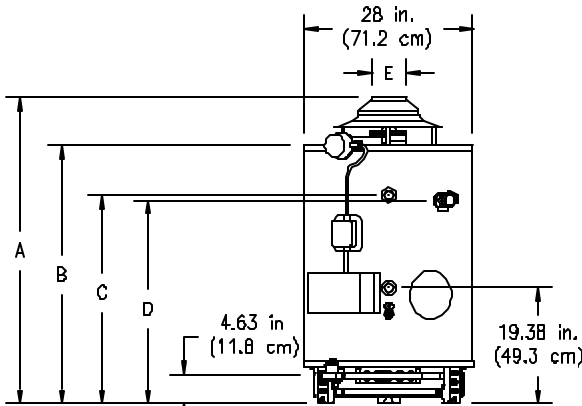

Figure 3

Flue Damper Models and Non-Flue Damper Models

Model Designation		A (in.)	B (in.)	C (in.)	D (in.)	E (in.)	Clearances *		
Capacity (GAL)	Input (BTU/hr)						Sides and Rear (in.)	Flue or Vent (in.)	Ceiling (in.)
38	155,000	51.00	43.00	34.75	33.75	6	2	6	20

Model Designation		A	B	C	D	E	Clearances *		
Capacity	Input						Sides and	Flue or	Ceiling

(Litres)	(kW/hr)	(m)	(m)	(m)	(m)	(cm)	Rear (cm)	Vent (cm)	(cm)
143.9	45.5	1.30	1.10	0.88	0.86	15.3	5.1	15.3	50.8

Installation (Minimum Clearances) continued-

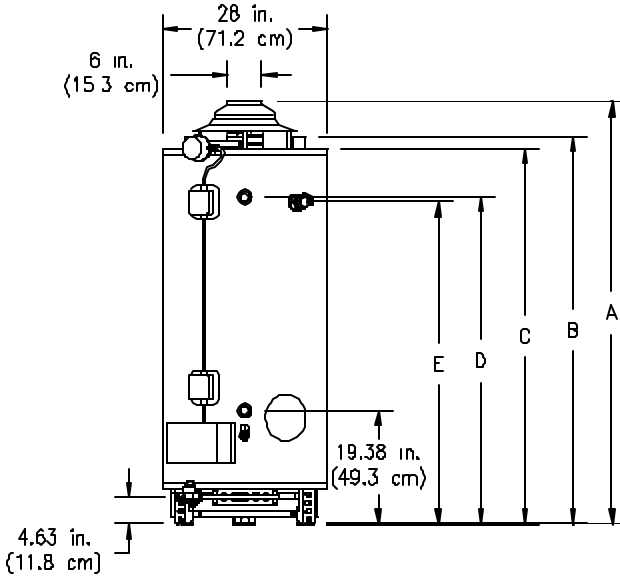

Figure 4

Non-Flue Damper Models

Model Designation		A (in.)	B (in.)	C (in.)	D (in.)	E (in.)	Clearances *		
Capacity (GAL)	Input (BTU/hr)						Sides and Rear (in.)	Flue or Vent (in.)	Ceiling (in.)
80	180,000	70.13	66.25	64.38	56.00	55.13	2	6	20
80	199,999 (235,000 LP)	70.13	66.25	64.38	56.00	55.13	2	6	20
80	250,000 (235,000 LP)	70.13	66.25	64.38	56.00	55.13	2	6	20
98	199,999	81.13	77.25	75.38	67.00	66.13	2	6	20
98	250,000 (235,000 LP)	82.88	77.25	75.38	67.00	66.13	2	6	20
100	199,999	75.50	69.88	61.88	60.38	56.88	2	6	20
100	250,000	75.50	69.88	61.88	60.38	56.88	2	6	20

Model Designation		A (m)	B (m)	C (m)	D (m)	E (m)	Clearances *		
Capacity (Liters)	Input (kW/hr)						Sides and Rear (cm)	Flue or Vent (cm)	Ceiling (cm)
302.8	52.8	1.79	1.69	1.64	1.43	1.40	5.1	15.3	50.8
302.8	58.7 (68.9 LP)	1.79	1.69	1.64	1.43	1.40	5.1	15.3	50.8
302.8	73.3 (68.9 LP)	1.79	1.69	1.64	1.43	1.40	5.1	15.3	50.8

371.0	52.8	2.06	1.97	1.92	1.71	1.68	5.1	15.3	50.8
371.0	73.3 (68.9 LP)	2.11	1.97	1.92	1.71	1.68	5.1	15.3	50.8
378.5	52.8	1.92	1.78	1.58	1.54	1.45	5.1	15.3	50.8
378.5	73.3	1.92	1.78	1.58	1.54	1.45	5.1	15.3	50.8

Installation (Minimum Clearances) continued-

Flue Damper Models (Figure 4)

Model Designation		A (in.)	B (in.)	C (in.)	D (in.)	E (in.)	Clearances *		
Capacity (GAL)	Input (BTU/HR)						Sides and Rear (in.)	Flue or Vent (in.)	Ceiling (in.)
80	180,000	71.88	66.25	64.38	56.00	55.13	2	6	20
80	199,999 (235,000 LP)	71.88	66.25	64.38	56.00	55.13	2	6	20
80	250,000 (235,000 LP)	71.88	66.25	64.38	56.00	55.13	2	6	20
98	199,999	82.88	77.25	75.38	67.00	66.13	2	6	20
98	250,000 (235,000 LP)	82.88	77.25	75.38	67.00	66.13	2	6	20
100	199,999	75.50	69.88	61.88	60.38	56.88	2	6	20
100	250,000	75.50	69.88	61.88	60.38	56.88	2	6	20

Model Designation		A (m)	B (m)	C (m)	D (m)	E (m)	Clearances *		
Capacity (Liters)	Input (kW/hr)						Sides and Rear (cm)	Flue or Vent (cm)	Ceiling (cm)
302.8	52.8	1.83	1.69	1.64	1.43	1.40	5.1	15.3	50.8
302.8	58.7 (68.9 LP)	1.83	1.69	1.64	1.43	1.40	5.1	15.3	50.8
302.8	73.3 (68.9 LP)	1.83	1.69	1.64	1.43	1.40	5.1	15.3	50.8
371.0	52.8	2.11	1.97	1.92	1.71	1.68	5.1	15.3	50.8
371.0	73.3 (68.9 LP)	2.11	1.97	1.92	1.71	1.68	5.1	15.3	50.8
378.5	52.8	1.92	1.78	1.58	1.54	1.45	5.1	15.3	50.8
378.5	73.3	1.92	1.78	1.58	1.54	1.45	5.1	15.3	50.8

The following notes apply to the tables accompanying Figures 1 - 4.

1. All models with flue dampers and/or above 400,000 BTU per hour input employ a "spark" (IID) ignition system and requires 120 volt AC electric supply.
2. * -Denotes minimum clearances to combustible material. Some models may have different clearances. Check the label on the front of the water heater to verify proper installation clearances.
3. Model number may have a suffix "N" for natural gas or "X", "P" or "L" for liquefied petroleum (LP) gases. Some models may have "A" as a suffix or prefix. Check the rating plate on front of the water heater for model number verification.

Venting

WARNING

The vent system must be installed properly. Failure to properly install the vent system could result in property damage, personal injury, or death.

This water heater must be connected to a masonry chimney or venting system approved by local codes or ordinances. The vent connector used to attach the draft diverter outlet to the chimney or approved vent must be of the same diameter as the draft diverter outlet or larger. For proper venting in certain installations, a larger vent connector may be needed. Consult venting tables in ANSI standard (Z223.1-or latest edition), National Fuel Gas Code and CAN/CGA (B149.1 or B149.2-latest editions), or local code officials for proper application for your area.

Flue Damper

Refer to Figure 5 and follow these instructions:

CAUTION

Do not turn on electrical power to water heater until flue damper is installed and water heater is filled with water.

1. Remove the damper from the accompanying box shipped within the crate.
2. Locate the collector outlet on top of the water heater. Place the damper over the collector outlet and rotate as necessary to a position in which the damper wiring plug can be fully engaged with the connector on the side of the water heater.
3. If applicable, remove clip which holds damper vane closed. This type of vent damper will then open by itself.
4. Secure the flue damper to the jacket top with sheet metal screws. Note: Some dampers require an additional bracket to assure level installation.
5. Connect the damper wiring plug to the connector on the side of the water heater. Note: The plug and connector can only be engaged one way (polarized).

Installation (Venting) continued-

- The Lighting and Operating instructions are outlined beginning on page 25. The damper must be in the open position when the water heater main burner is operating (the arrow on the damper plate is in the "up" position when open. Be certain the arrow is in a visible position when installed).

Draft Diverter

This water heater has been shipped with a draft diverter for which it was designed. Remove the bag containing the legs and instructions from the draft diverter. Attach the legs to the draft diverter and attach the draft diverter to the water heater per the instructions in the bag.

▲CAUTION

Modification to the flue damper or the draft diverter may result in personal injury, property damage or death. The flue damper and draft diverter are to be placed in position and operate exactly as stated in these instructions without modification.

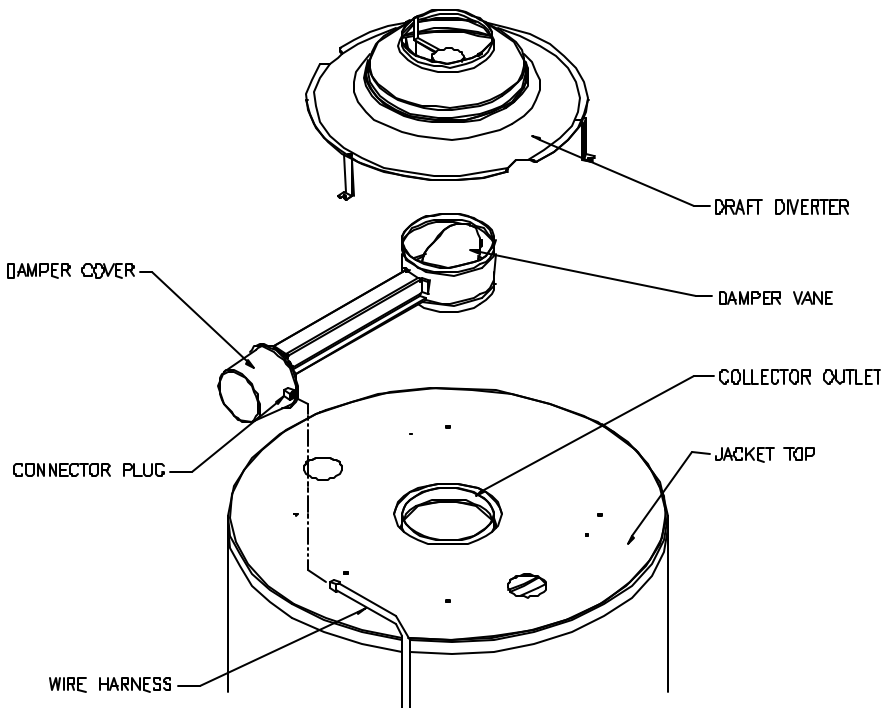

Figure 5

Combustion Air Supply

WARNING

Liquefied petroleum gases/propane gas are heavier than air and will remain at floor level if there is a leak. Basements, crawl spaces, closets and areas below ground level will serve as pockets for accumulation of leaking gas. Before lighting, smell all around the appliance area for gas. Be sure to smell next to the floor.

IF YOU SMELL GAS:

- Do not try to light any appliance.
- Do not touch any electric switch; do not use any telephone in your building.
- Immediately call your gas supplier from a telephone in another building. Follow the gas supplier's instructions.
- If you cannot reach your gas supplier, call the fire department.

DO NOT OPERATE APPLIANCE UNTIL LEAKAGE IS CORRECTED!

IMPORTANT

The flow of combustion and ventilating air must not be obstructed.

Provide adequate air for combustion and ventilation. An insufficient supply of air will cause recirculation of combustion products resulting in air contamination that may be hazardous to life. Such a condition often will result in a yellow, luminous burner flames, causing carboning or sooting of the burners and flue tubes with possible damage to the heater.

Confined Spaces

If the water heater is installed in a confined space (volume is less than 50 ft.³/1000 BTU (15 m³/0.29 kW) per hour of the total input rating of all gas appliances in that space), air must be supplied through two permanent openings. One opening shall be within 12 inches (30.5 cm) from the top of the enclosure and one within 12 inches (30.5 cm) of the bottom. The openings must be protected by metal louvers or 1/4" (6.4 mm) min. mesh metal screen. The size of the openings are as follows.

1. If the openings communicate directly with an additional room(s) of sufficient volume, each opening shall have a minimum free area opening of 1 in.²/1000 BTU (2.54cm²/0.29kW) per hour of the total input rating of all gas appliances in the confined space, but not less than 100 in.² (254 cm²).

Installation (Combustion Air Supply) continued-

2. If the openings communicate with the outdoors through horizontal ducts, each opening shall have a minimum free area of 1 in.²/2000 BTU (2.54cm²/0.59kW) per hour of the total rating of all gas appliances in the enclosure.
3. If the openings communicate directly with the outdoors or through vertical ducts with the outdoors, each opening shall have a minimum free area of 1 in.²/4000 BTU (2.54cm²/1.18kW) per hour of the total rating of all gas appliances in the enclosure.

▲ CAUTION

The draft diverter relief opening of the water heater and combustion air inlet must be in the same atmospheric pressure zone. Large exhaust fans in kitchens and other locations can lower the air pressure inside an enclosure and interfere with the proper operation and venting of the water heater . In these cases, the water heater should be installed in a separate room with the combustion and ventilation air supplied directly from outdoors as previously described.

All Air From Inside the Building: The confined space shall be provided with two permanent openings communicating directly with an additional room(s) of sufficient volume so that the combined volume of all spaces meets the criteria for an unconfined space. The total input of all gas utilization equipment installed in the combined space shall be considered in making this determination. Each opening shall have a minimum free area of 1 in.²/1000 BTU (2.54cm²/0.29kW) per hour of the total input rating of all gas utilization equipment in the confined space, but not less than 100 square inches (254cm²). One opening shall be within 12 inches (30.5 cm) of the top and one within 12 inches (30.5 cm) of the bottom of the enclosure.

Unconfined Spaces

In unconfined spaces in buildings, infiltration may be adequate to provide air for combustion, ventilation and dilution of flue gases. However, in buildings of tight construction (for example, weather stripping, heavily insulated, caulked, vapor barrier, etc.), additional air may need to be provided using the methods described above under **CONFINED SPACES: All Air From Outdoors or SPECIALLY ENGINEERED INSTALLATIONS.**

Specially Engineered Installations

The requirements noted under **CONFINED SPACES** above shall not necessarily govern when special engineering, approved by the authority having jurisdiction, provides an adequate supply of air for combustion, ventilation, and dilution of flue gases.

Water Connections

Note: BEFORE PROCEEDING WITH THE INSTALLATION, CLOSE THE MAIN WATER SUPPLY VALVE.

After shutting off the main water supply, open a faucet to relieve the water line pressure to prevent any water from leaking out of the pipes while making the water connections to the water heater. After the pressure has been relieved, close the faucet. The COLD water inlet and HOT water outlet are identified on the top and front of the water heater. Make sure the diptube is in place before making the cold water connection. Make the proper plumbing connections between the water heater and the plumbing system to the house. Install a shut-off valve in the cold water supply line.

CAUTION

If sweat fittings are to be used, **DO NOT** apply heat to the nipples on top or side of the water heater. Sweat the tubing to the adapter before fitting the adapter to the water connections. It is imperative that heat is not applied to the nipples containing a plastic liner.

WARNING

FAILURE TO INSTALL AND MAINTAIN A NEW, LISTED TEMPERATURE AND PRESSURE RELIEF VALVE WILL RELEASE THE MANUFACTURER FROM ANY CLAIM WHICH MIGHT RESULT FROM EXCESSIVE TEMPERATURE AND PRESSURES.

If this water heater is installed in a closed water supply system, such as the one having a back-flow preventer in the cold water supply, provisions shall be made to control thermal expansion. **DO NOT** operate this water heater in a closed system without provisions for controlling thermal expansion. Warranties do not cover damages from thermal expansions such as pressure bulges and/or deformities. Your water supplier or local plumbing inspector should be contacted on how to control this situation

After installation of the water lines, open the main water supply valve and fill the water heater. While the water heater is filling, open several hot water faucets to allow air to escape from the water system. When a steady stream of water flows through the faucets, close them and check all water connections for possible leaks. **NEVER OPERATE THE WATER HEATER WITHOUT FIRST BEING CERTAIN IT IS FILLED WITH WATER.**

CAUTION

Keep clear of combination temperature and pressure relief valve discharge line outlet. The discharge may be hot enough to cause scald injury. The water is under pressure and may splash.

WARNING

For protection against excessive temperatures and pressure, install temperature and pressure protective equipment required by local codes, but not less than a combination temperature and pressure relief valve certified by a nationally recognized testing laboratory that maintains periodic inspection of production of listed equipment or materials as meeting the requirements of the Standard for *Relief Valves and Automatic Gas Shutoff Devices for Hot Water Supply Systems, ANS Z21.22* and the Standard *CAN1-4.4 Temperature, Pressure, Temperature and Pressure Relief Valves and Vacuum Relief Valves*. The combination temperature and pressure relief valve shall be marked with a maximum set pressure not to exceed the maximum working pressure of the water heater. The combination temperature and pressure relief valve shall also have an hourly rated temperature steam BTU discharge capacity not less than the hourly rating of the water heater.

Install the combination temperature and pressure relief valve into the opening provided and marked for this purpose on the water heater.

Note: Some models may already be equipped or supplied with a combination temperature and pressure relief valve. Verify that the combination temperature and pressure relief valve complies with local codes. If the combination temperature and pressure relief valve does not comply with local codes, replace it with one that does. Follow the installation instructions above on this page.

Install a discharge line so that water discharged from the combination temperature and pressure relief valve will exit within six (6) inches (15.2 cm) above, or any distance below the structural floor and cannot contact any live electrical part. The discharge line is to be installed to allow for complete drainage of both the combination temperature and pressure relief valve and the discharge line. The discharge opening must not be subjected to blockage or freezing. **DO NOT** thread, plug or cap the discharge line. It is recommended that a minimum clearance of four (4) inches (10.2 cm) be provided on the side of the water heater for servicing and maintenance of the combination temperature and pressure relief valve.

Do not place a valve between the combination temperature and pressure relief valve and the tank.

▲WARNING

Hydrogen gas can be produced in an operating water heater that has not had water drawn from the tank for a long period of time (generally two weeks or more). Hydrogen gas is extremely flammable. To prevent the possibility of injury under these conditions, we recommend the hot water faucet to be open for several minutes at the kitchen sink before you use any electrical appliance which is connected to the hot water system. If hydrogen is present, there will be an unusual sound such as air escaping through the pipes as hot water begins to flow. **Do not smoke or have open flame near the faucet at the time it is open.**

This water heater can deliver scalding temperature water at any faucet in the system. Be careful whenever using hot water to avoid scalding injury. Certain appliances such as dishwashers and automatic clothes washers may require increased temperature water. By setting the thermostat on this water heater to obtain the increased temperature water required by these appliances, you may create the potential for scald injury. To protect against injury, you should install an ASSE approved mixing valve in the water system. This valve will reduce point of discharge temperature by mixing cold and hot water in branch supply lines. Such valves are available from the manufacturer of this water heater or a local plumbing supplier. Please consult with a plumbing professional. For information regarding space heating water connections and plumbing arrangements, refer to page 40.

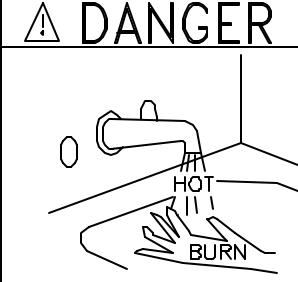
<p>Water temperatures over 125°F can cause severe burns instantly or death from scalds.</p> <p>Children, disabled, and elderly are at highest risk of being scalded.</p> <p>See instruction manual before setting thermostat at water heater.</p> <p>Feel water before bathing or showering.</p> <p>Temperature limiting valves are available, see manual.</p>

Gas Connections

The gas supply lines must meet all requirements of the National Fuel Gas Code (ANSI Z223.1-Latest Edition), or in Canada CAN/CGA B149.1 Natural Gas Installation Code (Latest Edition) or CAN/CGA B149.2 Propane Installation Code (Latest Edition).

The minimum permissible gas supply pressure for the purpose of input adjustment is one (1.0) inch (0.25 kPa) water column above the operating manifold pressure. See the rating plate and gas valve for the manifold pressure and gas type. The maximum permissible gas supply pressure is fourteen (14.0) inches (3.5 kPa) water column for natural gas and liquefied petroleum gases/propane gas.

1. Connect this water heater only to the type of gas (Natural or Propane gas) as shown on the rating plate. Use clean black iron pipe or equivalent material approved by local codes and ordinances. (Dirt and scale from the pipe can enter the gas valve and cause it to malfunction). The inlet gas line must have a minimum length of three (4) inches (7.6 cm) drip leg (*sediment trap*) installed as close to the water heater's gas valve as possible. A ground joint union must be installed in the gas supply line, as close to the water heater as possible, feeding the water heater to permit servicing of the water heater. Compounds used on the threaded joints of the gas piping must be resistant to the action of liquefied petroleum gases/propane gas. DO NOT apply pipe dope to the gas valve inlet and make certain that no pipe dope has become lodged in the inlet screen of the gas valve. Extreme care shall be taken to ensure no pipe dope enters the gas valve and to avoid excessive torque when tightening the gas supply line to the gas valve. Excessive torque may result in cracking of the gas valve housing. The suggested maximum torque is 31.5 ft. lbs. (4.4 kg-m). The manufacturer of this water heater will not be liable for any damage or injury caused as a result of a cracked gas inlet as a result of excessive torque.
2. This water heater and its gas connection must be leak tested before placing the water heater in operation. Check for gas leaks with a soap and water solution and a brush or a commercial leak detector fluid. **NEVER USE A MATCH OR OPEN FLAME FOR TESTING!**

CAUTION

The water heater and individual shutoff valve must be disconnected from the gas supply piping system during any pressure testing of the system at test pressures in excess of 1/2 psi (3.5 kPa). The water heater must be isolated from the gas supply piping system by closing its manual shutoff valve during any pressure testing of the gas supply system at test pressures equal to or less than 1/2 psi (3.5 kPa). The supply line must be capped when not connected to the water heater.

GENERAL OPERATION

WARNING

Water heaters are heat producing appliances. To avoid damage or injury there shall be no materials stored against the water heater or vent-air intake system, and proper care shall be taken to avoid unnecessary contact (especially by children) with the water heater and vent-air intake system.

UNDER NO CIRCUMSTANCES SHALL FLAMMABLE MATERIALS, SUCH AS GASOLINE OR PAINT THINNER BE USED OR STORED IN THE VICINITY OF THIS WATER HEATER OR IN ANY LOCATION FROM WHICH FUMES COULD REACH THE WATER HEATER.

TO FILL THE WATER HEATER

1. Close the water heater drain valve by turning the knob clockwise. If alternative water connections are provided but not used, make certain they are plugged (i.e. rear connections).
2. Open the cold water supply shut-off valve.
3. Open several hot water faucets to allow air to escape from the system.
4. When a steady stream of water flows from the faucets, the water heater is filled. Close the faucets and check for water leaks at the water heater drain valve, combination temperature and pressure relief valve and the hot and cold water connections.

TO DRAIN THE WATER HEATER

Should it become necessary to completely drain the water heater, make sure you follow the steps below:

1. Rotate the thermostat dial clockwise to the "PILOT LIGHTING" position.
2. Rotate and partially depress gas control knob clockwise to the "OFF" position.
3. Shut off the gas supply to the water heater.
4. Close the cold water supply shut-off valve.
5. Open the drain valve on the water heater by turning the knob counter-clockwise. The drain valve has threads on the end that will allow the connection of a standard hose coupling.
6. Open a hot water faucet to allow air to enter the system.

To refill the water heater, refer to "To Fill the Water Heater."

General Operation (Standing Pilot Wiring Diagram) continued-

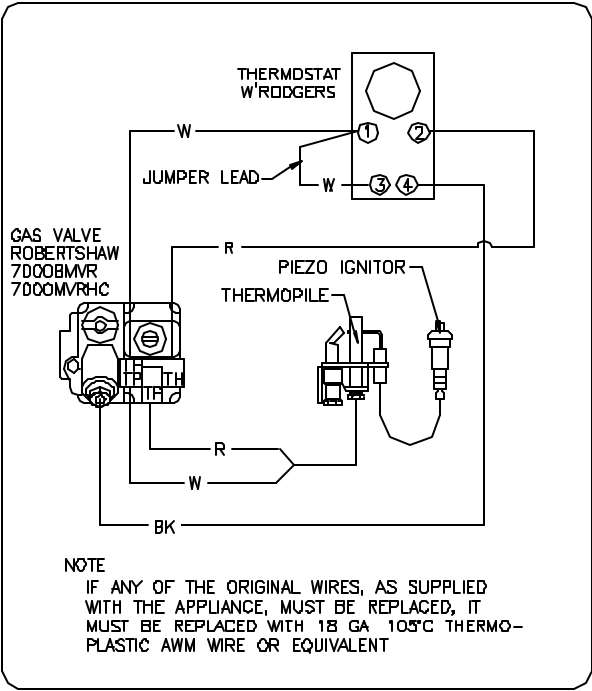

General Operation (Spark Ignition Pilot Wiring Diagram) continued-

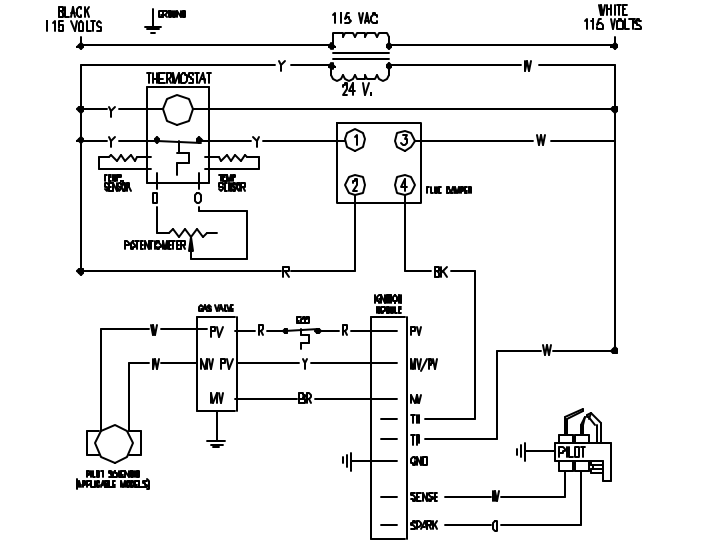
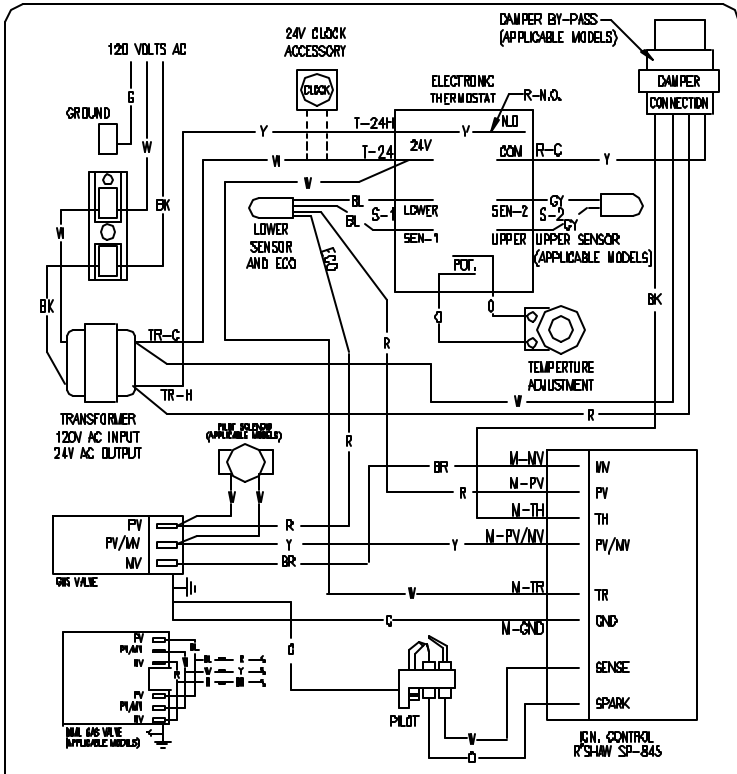

NOTE:
 IF ANY OF THE ORIGINAL WIRES AS SUPPLIED WITH THE APPLIANCE MUST BE REPLACED.
 IT MUST BE REPLACED WITH 18, GA STRANDED 105° WIRE OR ITS EQUIVALENT.

Lighting And Shutdown Instructions

Standing Pilot Models

FOR YOUR SAFETY READ BEFORE LIGHTING

WARNING: If you do not follow these instructions exactly, a fire or explosion may result causing property damage, personal injury or loss of life



- A This appliance has a pilot which must be lighted by hand. When lighting the pilot, follow these instructions exactly.
- B. **BEFORE OPERATING** smell all around the appliance area for gas. Be sure to smell next to the floor because some gas is heavier than air and will settle on the floor.
- WHAT TO DO IF YOU SMELL GAS**
- Do not try to light any appliance.
 - Do not touch any electric switch; do not use any phone in your building.
 - Immediately call your gas supplier from a neighbors phone. Follow the gas supplier's instructions.
- If you cannot reach your gas supplier, call the fire department.
- C Use only your hand to push in or turn the gas control knob. Never use tools. If the knob will not push in or turn by hand, don't try to repair it, call a qualified service technician. Force or attempted repair may result in a fire or explosion.
- D. Do not use this appliance if any part has been under water. Immediately call a qualified service technician to inspect the appliance and to replace any part of the control system and any gas control which has been under water.

LIGHTING INSTRUCTIONS

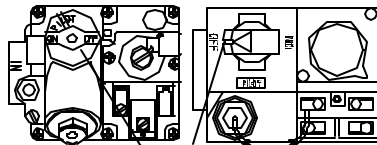
1. **STOP!** read the safety information above on this label
2. Set the thermostat to lowest setting.
3. Turn off all electric power to the appliance.
4. Push in gas control knob slightly and turn clockwise  to "OFF."



GAS CONTROL KNOB SHOWN IN "OFF" POSITION

5. Wait (5) minutes to clear out any gas. If you then smell gas, **STOP!** Follow "B" in the safety information above on this label. If you don't smell gas, go to next step.
6. Find pilot - follow metal tube from gas control. The pilot is located in the center of the burner rack between two burner tubes.
7. Turn knob on gas control counterclockwise  to "PILOT."
8. Push in control knob all the way and hold in. Immediately light the pilot with a match. Continue to hold the control knob in for about (1) minute after the pilot is lit. Release knob and it will pop back up. Pilot should remain lit. If pilot goes out, repeat steps 4 thru 8.
 - If knob does not pop up when released, stop and immediately call your service technician or gas supplier.
 - If the pilot will not stay lit after several tries, turn the gas control knob to "OFF" and call your service technician or gas supplier.
9. Turn gas control knob counterclockwise  to "ON"
10. Turn on all electric power to the appliance.
11. Set the thermostat to desired setting.

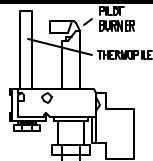

TO TURN OFF GAS TO APPLIANCE

1. Set the thermostat to lowest setting.
2. Turn off all electric power to the appliance if service is to be performed.
3. Push in gas control knob slightly and turn clockwise  to "OFF." Do not force.

Spark Ignition Pilot Models

FOR YOUR SAFETY READ BEFORE LIGHTING

WARNING: If you do not follow these instructions exactly, a fire or explosion may result causing property damage, personal injury or loss of life.

- A. This appliance is equipped with an ignition device which automatically lights the pilot. Do **not** try to light the pilot by hand.
- B. **BEFORE OPERATING** smell all around the appliance area for gas. Be sure to smell next to the floor because some gas is heavier than air and will settle on the floor.
- WHAT TO DO IF YOU SMELL GAS**
- ◆ Do not try to light any appliance.
 - ◆ Do not touch any electric switch; do not use any phone in your building.
 - ◆ Immediately call your gas supplier from a neighbor's phone. Follow the gas supplier's instructions.
- ◆ If you cannot reach your gas supplier, call the fire department.
- C. Use only your hand to push in or turn the gas control knob. Never use tools. If the knob will not push in or turn by hand, don't try to repair it, call a qualified service technician. Force or attempted repair may result in a fire or explosion.
- D. Do not use this appliance if any part has been under water. Immediately call a qualified service technician to inspect the appliance and to replace any part of the control system and any gas control which has been under water.

OPERATING INSTRUCTIONS

1. **STOP!** read the safety information above on this label
2. Set the thermostat to lowest setting.
3. Turn off all electric power to the appliance.
4. This appliance is equipped with an ignition device which automatically lights the pilot. Do not try to light the pilot by hand.
5. Turn gas control knob clockwise ↷ to "off".
6. Wait five (5) minutes to clear out any gas. If you then smell gas, **STOP!** Follow "B" in the safety information above on this label. If you don't smell gas, go to next step.
7. Turn gas control knob counterclockwise ↶ to "ON."
8. Turn on all electric power to the appliance.
9. Set thermostat to desired setting.
10. If the appliance will not operate, follow the instructions "To Turn Off Gas To Appliance" and call your service technician or gas supplier.

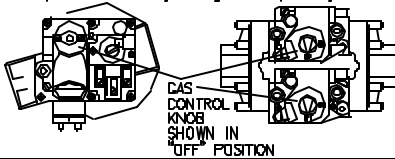

TO TURN OFF GAS TO APPLIANCE

1. Set the thermostat to lowest setting.
2. Turn off all electric power to the appliance if service is to be performed.
3. Turn gas control knob clockwise ↷ to "OFF."

General Operation continued

Temperature Adjustment

The temperature selector knob of the thermostat has been adjusted to its lowest setting when shipped from the factory.

The detent on the thermostat temperature scale (shown below) is the preferred starting point for setting the temperature control. For energy-efficient operation of your water heater, the suggested initial temperature setting is approximately 130°F (55°C). Households with small children or invalids may require a 120°F (49°C) or lower temperature setting to reduce the risk of scald injury. Some states require a lower temperature setting. Full counterclockwise rotation of the temperature selector knob is the minimum temperature setting. Full clockwise rotation of the temperature selector knob is the maximum temperature setting. NOTE: The lower the temperature setting, the greater the energy efficiency, both to heat the water and to maintain its temperature during standby periods. Lower water temperatures also extend tank life. Remember, no water heating system will provide exact temperatures at all times. Allow a few days of operation at this setting to determine the correct temperature setting consistent with your needs. NOTE: This water heater, when set at a lower temperature setting, is not capable of producing hot water of sufficient temperature for sanitizing purposes.

During winter season or any cold period, you may desire a higher temperature setting to adjust for the colder incoming water. This adjustment, however, may cause additional condensation to form on the cooler tank surface. This does not mean the tank is leaking. During summer months, the warmer incoming water temperatures will benefit the performance of your water heater and reduce the amount of condensation developed.

Condensation does not mean your tank is leaking. Over 40% of reported tank leaks on installation are proven to be condensation. To avoid unnecessary expense and inconvenience, make sure the tank is leaking before calling a service person.

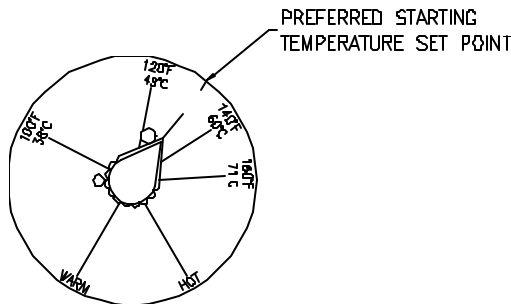

Figure 6

General Operation (Temperature Adjustment) continued-

⚠ DANGER

Hotter water increases the risk of scald injury. Scalding may occur within five (5) seconds at a temperature setting of 135°F (57°C). To protect against hot water injury, install an ASSE approved mixing valve in the water system. This valve will reduce point of discharge temperature by mixing cold and hot water in branch water lines. A licensed plumbing professional or local plumbing authority should be consulted.

Note: This water heater is equipped with an energy cut out device to prevent overheating. Should overheating occur or the gas supply fail to shut off, turn off the manual gas control valve to the appliance and call a qualified service technician.

Note: Whenever the water heater is filled with cold water, condensate will form on the cool tank surface and drops of water will fall on the hot burner and combustion chamber surfaces producing a “sizzling” noise. Condensation is normal and does not indicate a leak. It will disappear when the tank becomes heated.

An automatic gas shut-off device (ECO) is incorporated in the thermostat which will shut off all gas supply to the burner and pilot if the water heater temperature exceeds 200°F (93°C). Should the ECO function (open), the water temperature should be reduced to approximately 120°F (49°C) and follow applicable Lighting Instructions (page 25 or 26) to place the water heater in operation. If a problem exists, contact your dealer for service. It is recommended that all service work be performed by a qualified service agency.

If the water heater is to remain idle for 30 days or more or is subjected to freezing temperatures while shut off, the water heater and piping should be fully drained (See page 22, “To Drain the Water Heater”) and the drain valve should be left fully open.

⚠ WARNING

Hydrogen gas can be produced in an operating water heater that has not had water drawn from the tank for a long period of time (generally two weeks or more). Hydrogen gas is extremely flammable. To prevent the possibility of injury under these conditions, we recommend the hot water faucet to be open for several minutes at the kitchen sink before you use any electrical appliance which is connected to the hot water system. If hydrogen is present, there will be an unusual sound such as air escaping through the pipes as hot water begins to flow. Do not smoke or have open flame near the faucet at the time it is open.

General Operation continued-

Burner Flame Check

At the time of installation and at periodic intervals (about every 3 months), a visual check of the pilot and burner flames should be made to determine if they are burning properly. No adjustment to the air shutter should be required for this heater. The burner flames should be blue with yellow tips. A blue-orange flame is characteristic of operation on liquefied petroleum (LP) gas. If the burner flame does not appear as described, an air shutter adjustment may be required. The burner tube flames should light smoothly from the pilot.

IMPORTANT

In the event of an emergency, turn off the gas and electric (if applicable) to the appliance.

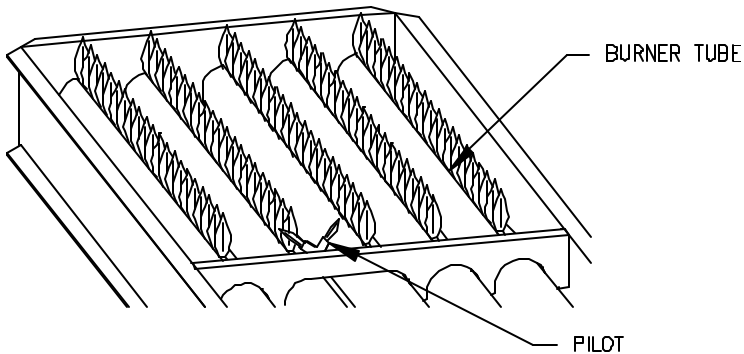
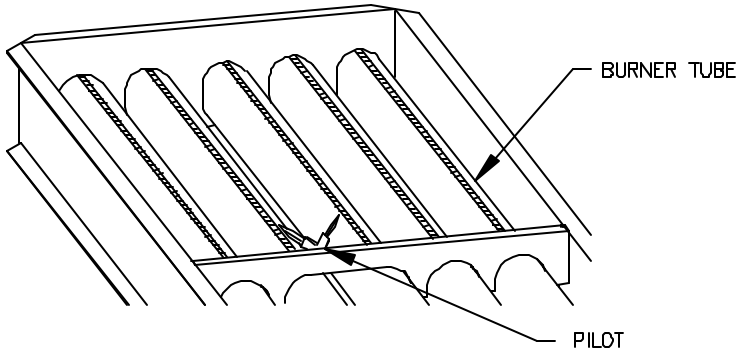

Figure 7

MAINTENANCE

WARNING

Water heaters are heat producing appliances. To avoid damage or injury there shall be no materials stored against the water heater or vent system, and proper care shall be taken to avoid unnecessary contact (especially by children) with the water heater and vent system. **UNDER NO CIRCUMSTANCES SHALL FLAMMABLE MATERIALS, SUCH AS GASOLINE OR PAINT THINNER BE USED OR STORED IN THE VICINITY OF THIS WATER HEATER, VENT SYSTEM OR IN ANY LOCATION FROM WHICH FUMES COULD REACH THE WATER HEATER OR VENT SYSTEM.**

IMPORTANT

The water heater should be inspected at a minimum annually by a qualified service technician for damaged components and/or joints not sealed. DO NOT operate this water heater if any part is found damaged or if any joint is found not sealed.

The following maintenance should be performed by a qualified service technician at the minimum periodic intervals suggested below. In some installations, the maintenance interval may be more frequent depending on the amount of use and the operating conditions of the water heater. Regular inspection and maintenance of the water heater will help to insure safe and reliable operation.

1. Annual checks of the ignition systems (millivolt and electronic), temperature controls and any other water heater controls are necessary to ensure proper operation. Also, all safety shut-off valves must be checked to verify proper operation and tightness.
2. The flow of combustion and ventilation air **MUST NOT** be restricted. Clear the combustion air openings of any dirt, dust, or other restrictions. **WARNING!** The combustion ventilation system may be **HOT**.
3. At all times keep the water heater area clear and free from combustible materials, gasoline and other flammable vapors and liquids.
4. Bi-annually conduct a visual check of the pilot and burner flames to determine that they are burning properly. See "Burner Flame Check" section on page 29 for example of proper burner flame pattern.

Maintenance continued-

5. Annually remove the main burner rack assembly to clean orifices and related parts of any dirt or other foreign material. Inspect the burner ports for obstructions or debris and clean with a wire brush, vacuum, or use a mild detergent solution to clean as needed. **NOTE:** It is imperative for proper operation of the water heater that the main burner rack be replaced in the original location.

▲WARNING

When lifting lever of the combination temperature and pressure relief valve, hot water will be released under pressure. Be careful that any released water does not result in bodily injury or property damage.

7. At least once a year, check the combination temperature and pressure relief valve to insure that the valve has not become encrusted with lime. Lift the lever at the top of the valve several times until the valve seats properly without leaking and operates freely.

IMPORTANT

If the combination temperature and pressure relief valve on the appliance discharges periodically, this may be due to thermal expansion in a closed water supply system. Contact the water supplier or local plumbing inspector on how to correct this situation. Do not plug the combination temperature and pressure relief valve outlet.

8. Monthly drain off a gallon of water to remove silt and sediment.
WARNING! This water may be **HOT**.
9. All models are equipped with a cleanout opening to aid in removal of hard water deposits from the tank bottom. If this water heater operates under hard water conditions, the following should be performed at least every 3 months: Drain the water heater. Remove the cleanout jacket cover and tank cover. When cleaning the tank, care must be taken to avoid trying to break deposits loose as this could damage the glass lining and shorten the life of the water heater. After cleaning, replace the cleanout tank cover and jacket cover, and refill with water.
10. A combination sacrificial anode rod/hot water outlet nipple has been installed to extend tank life. The anode rod should be inspected periodically (every 2 years) and replaced when necessary to prolong tank life. Water conditions in your area will influence the time interval for inspection and replacement of the anode rod. Contact the plumbing professional who installed the water heater or the manufacturer listed on the rating plate for anode replacement information. The use of a water softener may increase the speed of anode consumption. More frequent inspection of the anode is needed when using softened (or phosphate treated) water.

Maintenance (continued)-

▲CAUTION

FOR YOUR SAFETY, DO NOT ATTEMPT REPAIR OF COMBINATION GAS CONTROL, BURNERS OR GAS PIPING. REFER REPAIRS TO A QUALIFIED SERVICE TECHNICIAN.

Contact your supplier, plumbing professional or contact the company at the address given on the rating plate of the water heater for replacement parts.

Provide the part name as well as the model and serial number(s) of the water heater(s) when ordering parts.

READ THE WARRANTY FOR A FULL EXPLANATION OF THE LENGTH OF TIME THAT PARTS AND THE WATER HEATER ARE WARRANTED.

Manufactured under one or more of the following U.S. Patents: Re. 34,534; 4,416,222; 4,628,184; 4,669,448; 4,672,919; 4,808,356; 4,829,983; 4,861,968; 4,904,428; 5,000,893; 5,023,031; 5,052,346; 5,081,696; 5,092,519; 5,115,767; 5,199,385; 5,277,171; B1 5,341,770; 5,372,185; 5,485,879; 5,574,822; 5,596,952; 5,660,165; 5,682,666; 5,761,379; 5,943,984; 5,954,492; 5,988,117. Other U.S. and Foreign patents applications pending. Current Canadian Patents: 1,272,914; 1,280,043; 1,289,832; 2,045,862; 2,112,525.

Complete the following information and retain for future reference:

Model No: _____

Serial No: _____

Service Phone

Days: _____ Nights: _____

Address: _____

Supplier: _____

Supplier Phone No: _____

TYPICAL INSTALLATION

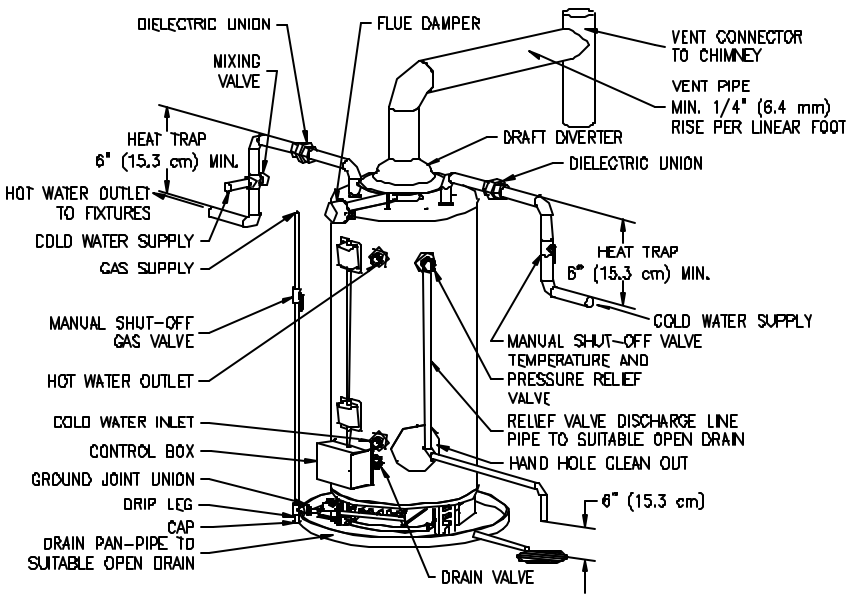

Sequence of Normal Operation (Standing Pilot with Milli-volt Control)

1. With the pilot lit, the pilot burner assembly power pile generates milli-voltage to energize the magnet coil in the gas valve permitting gas flow through pilot and to the main gas ports of the valve. Simultaneously milli-voltage is also directed to the ECO (energy cut off) switches located in the thermostat.
2. Set the control knob on the gas valve to "ON" position.
3. Set the adjustable thermostat to desired water temperature.
4. As the water temperature decreases below the thermostat setting in the tank, the contacts in the thermostat will close, thereby energizing the circuit to the main valve permitting the flow of gas to the main burner.
5. A slow opening feature of the gas valve will cause the burners to light slowly at a reduced manifold pressure. After a few seconds (allowing the combustion system to stabilize), the manifold pressure will increase to the maximum setting of the gas valve.
6. The burners will continue to fire until the thermostat becomes satisfied, where upon the contacts will open, de-energize the main valve circuit, and the burners will extinguish.
7. If the temperature rises above fixed ECO (energy cut off) setting, the ECO contacts will open simultaneously de-energizing pilot and main valve circuits, and the burners will be extinguished.

Operating and Troubleshooting Guide - Sequence of Normal Operation (Electronic Thermostat with Intermittent Pilot Ignition)

1. The electronic thermostat controls the 24-volt circuit to the ignition control. When the thermostat contacts close, a 24-volt circuit is completed from the transformer through the thermostat relay to the ignition control module to initiate the ignition sequence.
2. On flue damper models, the damper reaches then full open position, the end switches in the damper close, completing the 24-volt circuit to the ignition module.
3. The ignition control sends 24-volt power to the pilot valve “PV” terminals on the gas valve allowing pilot gas to flow to the pilot. The ignition control also simultaneously sends high voltage low current electricity through the electrode wire to the pilot electrode causing sparks at the pilot electrode to ignite the pilot gas. If the pilot fails to ignite within 90 seconds, the ignition control stops the pilot gas and sparking for 15 seconds to allow gas to dissipate. The ignition control will then attempt 2 (two) more ignition trials as stated above. If the pilot does not ignite after 3 trials, the ignition control will then go into “lockout mode”, and the ignition system will remain shut down until the control is reset by interrupting power to the ignition module.
4. When the pilot gas ignites, the flame is sensed by the electrode or a flame sensing rod. The flame sensing signal received by the ignition control causes the sparking to stop and the main gas valve to open. The main burners ignite from the pilot flame. The pilot flame is continually monitored by the flame sensing circuit. If for any reason, the pilot flame is not sensed by the electrode or flame sensing rod, the main gas valve closes, the spark electrode is reenergized, and the ignition trial period is reestablished. The same sequence occurs during a power or gas supply interruption.
5. The main burners continue to operate until the water temperature in the tank increases enough to cause the thermostat contacts to open. When the thermostat contacts open the 24-volt power is interrupted to the ignition control module and the gas valve closes. The flue damper (on “D” models) closes.
6. If for some reason thermostat contacts fail to open, then the high temperature limit (ECO) contacts in the thermostat sensor open and interrupts power to the pilot valve causing the pilot to extinguish. The ignition module senses the pilot outage and attempts to relight the pilot by reestablishing the sparking at the electrode as stated in paragraph 3 above. Since the pilot valve circuit is open, the pilot will not ignite and the system will go into “lockout mode” after 3 ignition trials. In the “lockout mode”, the ignition system will remain shutdown until the control is reset by interrupting power to the ignition module. The ECO will not reset to close the contacts until the tank water temperature drops to between 100°F (38°C) and 160°F (71°C). If the ECO contacts open, the cause for the high water temperature should be determined before resetting the ignition system.

Troubleshooting Procedure for Electronic Thermostat

If water temperature is too hot, proceed as follows:

Test or Condition:	Result:	Action Taken:
Start - Disconnect sensor leads from electronic control module and measure resistance of sensor(s) with ohmmeter	Is resistance between 700 and 30K ohms (see page 38)? YES↓ NO→	Sensor(s) may be shortened or open. Check for loose, broken or shorted wires. Replace sensing bulb(s) if necessary.
Sensors O.K. Disconnect ECO leads and measure resistance with ohmmeter	Is water temperature greater than 210°F (99°C) and ECO resistance less than 10 ohms (shorted)? YES→ NO↓	Replace sensing bulb with ECO limit and check out balance of system.
Disconnect potentiometer leads from electronic control module. Measure resistance of potentiometer with ohmmeter.	Is resistance greater than 4800 ohms at minimum temperature setting (checks for short)? YES↓ NO→	Replace electronic control module. Reconnect all leads and check out system
Potentiometer O.K.		Replace electronic control module. Reconnect all leads and check out system

If water temperature is too cold or heater does not come on, proceed as follows:

Test or Condition:	Result:	Action Taken:
Start: Check voltage at 24-volt terminals of electronic control module of thermostat board.	Is voltage between 21.5 and 28.5 VAC? YES↓ NO→	Check power supply, transformer. Correct as necessary.
Are main burners operating or is pilot trying to light (sparking)? YES↓ NO→	Check for voltage at N.O. thermostat terminals (terminal to meter to ground). Is voltage between 21.5 and 28.5 VAC? YES↓ NO→	Thermostat relay is not closing. Check thermostat setting. Refer to thermostat troubleshooting below.

Troubleshooting Procedure for Electronic Thermostat (continued)-

If water temperature is too cold or heater does not come on, proceed as follows:

Test or Condition:	Result:	Action Taken:
Are burners operating?	If pilot does not light and pilot is not sparking, check to make sure flue damper is in the full open position. Damper opens? YES↓ NO→	Check flue damper wiring. Check for 24 volts at yellow wire from thermostat to damper. If damper still does not open check for 24 volts between red and white wires to damper. If damper does not open when voltage is present and thermostat is closed, replace damper operator.
	If damper opens, but pilot does light or spark:	Check black wire from damper for 24 volts to ground. If no voltage is present, but damper is open and voltage is present between yellow wire and ground, end switch in damper may be faulty. Replace damper operator.
	Does pilot spark without lighting pilot? Make sure there is sufficient gas pressure at the gas valve inlet. Check the nameplate for minimum gas supply pressures for the type of gas used. Check for plugged pilot orifice.	If the pilot valve will not open when voltage is present to the to the PV terminal and the common terminal "PV/MV" wire has continuity to the module, the gas valve may be defective. If no voltage is present at "PV" on the ignition control and the ECO is closed (power to 24V and 24V GND terminals of module) the ignition control module may be defective. Replace and recheck system.
	Check gas valve by measuring voltage from "PV" to ground. If no voltage, check continuity across ECO circuit of thermostat (red wires). If ECO is open, it should reset after tank cools below 160°F (71°C). If it does not reset, replace sensing bulb with the ECO. If ECO has opened, there may be a problem with the thermostat.	Make sure pilot flame is steady and envelopes the electrode or flame sensor. Turn pilot adjustment screw counter-clockwise to increase size of pilot flame. Make sure pilot shield is in place.

Pilot lights, but main gas does not come on.

If pilot flame is stable, check for voltage at the "MV" terminal at the ignition module and gas valve. If no voltage is present at the ignition module, replace control. If voltage is present at the gas valve, replace valve.

Troubleshooting Procedure for Electronic Thermostat (continued)-

If water temperature is too cold or heater does not come on, proceed as follows (continued from table above):

Test or Condition:	Result:	Action Taken:
<p>If power is not present at the "NO" terminal of the thermostat board, and the heater operates if this wire is jumpered to the "COM" terminal above it, then make the following checks to the thermostat circuit. This procedure also applies if the burners cycle on for short periods, but the water temperature seems low.</p>	<p>Disconnect sensor leads from electronic control module and measure resistance of sensor(s) with ohmmeter. Is resistance between 700 and 30K ohms (see page 38)? Measure water temperature from tank for an approximate correlation with the table. YES↓ NO→</p>	<p>Sensor(s) may be shorted or open. Check continuity of wires for loose, broken, or shorted wires. Replace sensing bulb or wire harness. If necessary.</p>
<p>Sensors O.K. Check remote potentiometer.</p>	<p>Disconnect potentiometer leads from electronic control module. Measure resistance of potentiometer with ohmmeter. Is resistance greater than 4800 ohms at the minimum temperature setting and less than 50 ohms at the maximum temperature setting (checks for open or shorts)? YES↓ NO→</p>	<p>Replace potentiometer. Reconnect all leads and check out system.</p>
<p>Potentiometer O.K.</p>		<p>Replace electronic control module. Reconnect all leads and check out system.</p>

Temperature Control Checkout Procedure

Set the L8104 above water temperature (See page 27) and observe system through one (1) complete cycle. Make sure system operates as desired.

To check the thermistor or thermistor/ECO assembly, compare it's resistance as measured by an ohmmeter to the water temperature as measured by an accurate thermometer. Thermistor resistance increases as the temperature decreases. The tables below show the correct sensor resistance at various temperatures.

In Degrees F										
°F	0	1	2	3	4	5	6	7	8	9
40	26109	25400	24712	24045	23399	22771	22163	21573	21000	20445
50	19906	19383	18876	18383	17905	17440	16990	16553	16128	15715
60	15314	14925	14548	14180	13823	13477	13140	12812	12494	12185
70	11884	11592	11308	11032	10763	10502	10248	10000	9760	9526
80	9299	9078	8862	8653	8449	8250	8057	7869	7685	7507
90	7333	7165	7000	6839	6683	6531	6383	6238	6098	5961
100	5827	5697	5570	5446	5326	5208	5094	4982	4873	4767
110	4663	4562	4464	4368	4274	4183	4094	4006	3922	3839
120	3758	3679	3602	3527	3453	3382	3312	3244	3177	3112
130	3048	2986	2925	2866	2808	2752	3697	3643	2590	2538
140	2488	2439	2391	2344	2298	2253	2209	2166	2124	2083
150	2043	2004	1966	1928	1891	1856	1820	1786	1753	1720
160	1688	1656	1625	1595	1566	1567	1509	1481	1454	1427
170	1402	1376	1351	1327	1303	1280	1257	1235	1213	1191
180	1170	1150	1129	1110	1090	1071	1053	1035	1017	999
190	982	965	949	933	917	901	886	871	857	842
200	828	814	801	788	775	762	749	737	725	713

In Degrees C										
°C	0	1	2	3	4	5	6	7	8	9
0	32648	31026	29495	28049	26682	25389	24166	23010	21915	20879
10	19898	18968	18088	17253	16461	15710	14998	14322	13680	13071
20	12492	11942	11419	10922	10450	10000	9572	9165	8778	8409
30	8057	7722	7403	7099	6808	6532	6268	6016	5775	5546
40	5327	5117	4917	4726	4543	4368	4201	4042	3889	3742
50	3602	3468	3340	3217	3099	2986	2878	2774	2675	2579
60	2488	2400	2316	2235	2157	2083	2011	1942	1876	1813
70	1752	1693	1637	1582	1530	1480	1432	1385	1340	1297
80	1256	1216	1177	1140	1105	1070	1037	1005	974	944
90	916	888	861	835	810	786	763	741	719	698

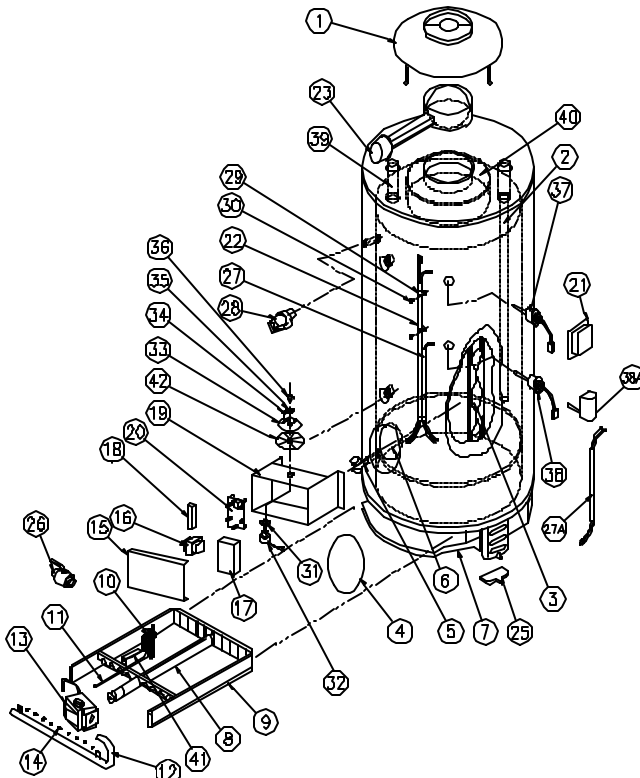

PART NAME AND DESCRIPTION

1. Drafthood	22. Wire Harness-Damper/Upper Sensor (S.I.)
2. Dip tube	23. Flue Damper (Spark Ignition Models)
3. Flue Baffle	24. Anode Rod (Not Pictured)
4. Cleanout Access (Jacket) Cover	25. Tank Leg Thermal Break
5. Drain Valve	26. Manual Shut Off Valve (Applicable Model) *
6. Cleanout Cover	27. Wire Harness-Lower Sensor (S.I. Models)
6a. Cleanout Cover O-Ring (Not Pictured)	27a. Wire Harness (Standing Pilot Models)
6b. Cleanout Cover Gasket A.S.M.E. (Not Pic)	28. T&P Valve
7. Heat Shield	29. Nylon Cable Clamp
8. Main Burner Tube(s)	30. Self Tapping Screw
9. Burner Tray	31. Gasket Potentiometer (S.I. Models)
10. Pilot Burner Assembly	32. Temp Control Potentiometer (S.I. Models) *
11. Pilot Supply Tube	33. Bezel Temp Control (S. I. Models)
12. Main Burner Manifold	34. Screw Bezel Position (S. I. Models)
13. Gas Valve *	35. Locknut Potentiometer (S. I. Models)
14. Main Burner Orifice	36. Temp Control Knob (S. I. Models)
15. Control Box Cover (Spark Ignition Models)	37. Upper Temp Sensor (S. I. Models)
16. Transformer (Spark Ignition Models)	38. Lower Temp Sensor (S. I. Models)
17. Ignition Module (Spark Ignition Models)	38a. Thermostat (Standing Pilot Models) *
18. Terminal Block (Spark Ignition Models)	39. Outlet Nipple
19. Control Box (Spark Ignition Models)	40. Collector Head
20. Thermostat Board (Spark Ignition Models)	41. Pilot Shield
21. Utility Cover	42. Scale Plate

* Denotes emergency shut-off devices.

THE FOLLOWING INSTRUCTIONS ARE FOR INSTALLATION OF: GAS WATER HEATERS SUITABLE FOR WATER (POTABLE) HEATING AND SPACE HEATING

1. All piping components connected to this water heater for space heating applications must be suitable for use with potable water. In Massachusetts, space heating piping length **must not** exceed 50 feet.
2. Toxic chemicals, such as those used for boiler treatment, **must not** be introduced into potable water used for space heating.
3. This water heater **must not** be connected to an existing heating system or component(s) previously used with a non-potable water heating appliance.
4. When the system requires water for space heating at temperatures higher than required for other means, such as an ASSE approved mixing valve shall be installed to temper the water for those uses in order to reduce the scald hazard potential.

Please refer to the illustrations below and on the following pages for suggested piping arrangements.

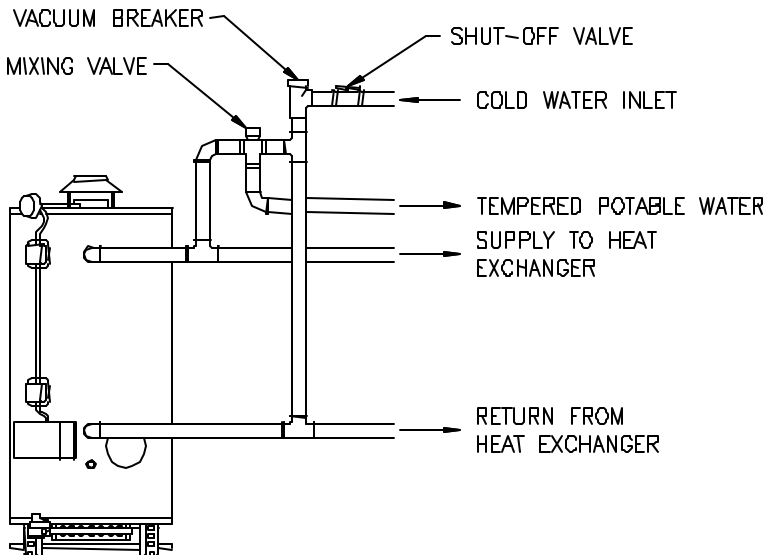

Suggested Piping Arrangement For Side Connections

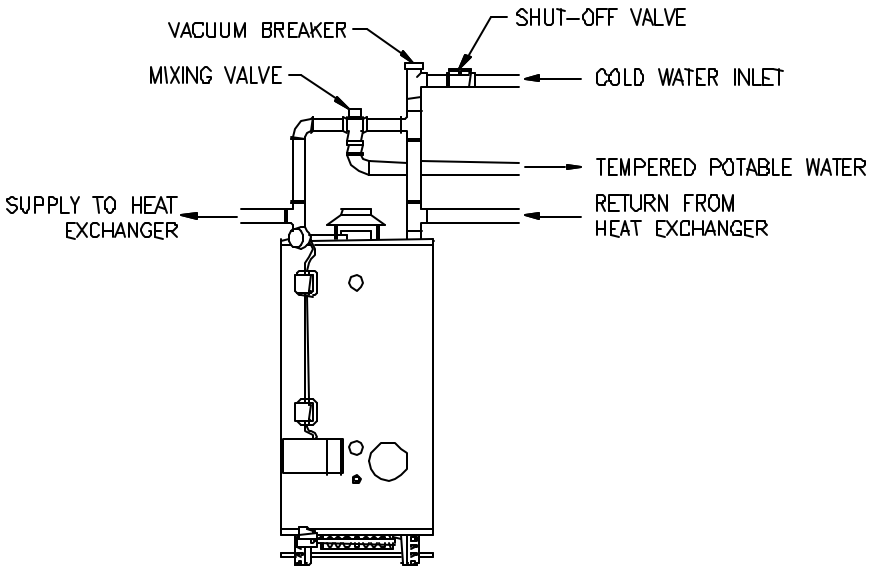

Suggested Piping Arrangement For Top Connections

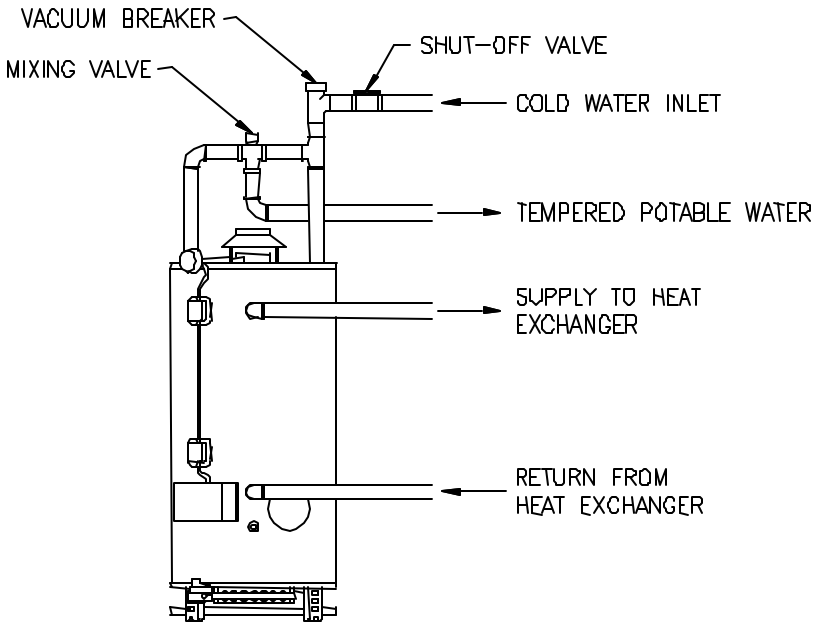

Suggested Piping Arrangement For Side Connections (If Applicable)

NOTES

NOTES